

Transportieren  
Transporting  
Transport

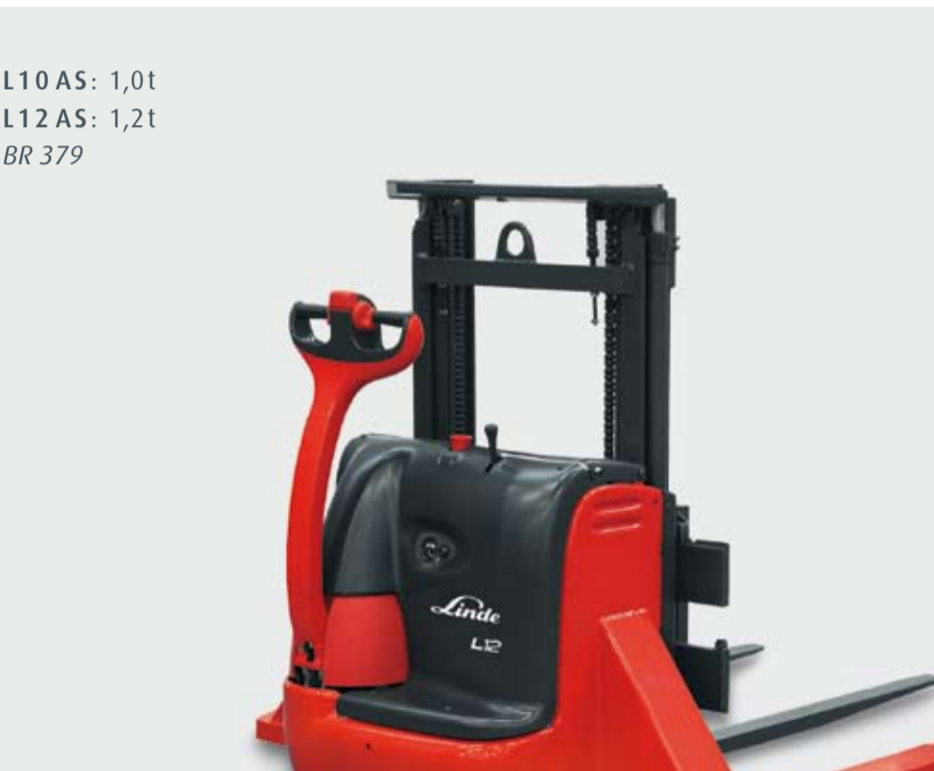

Lagern  
Storage  
Stockage

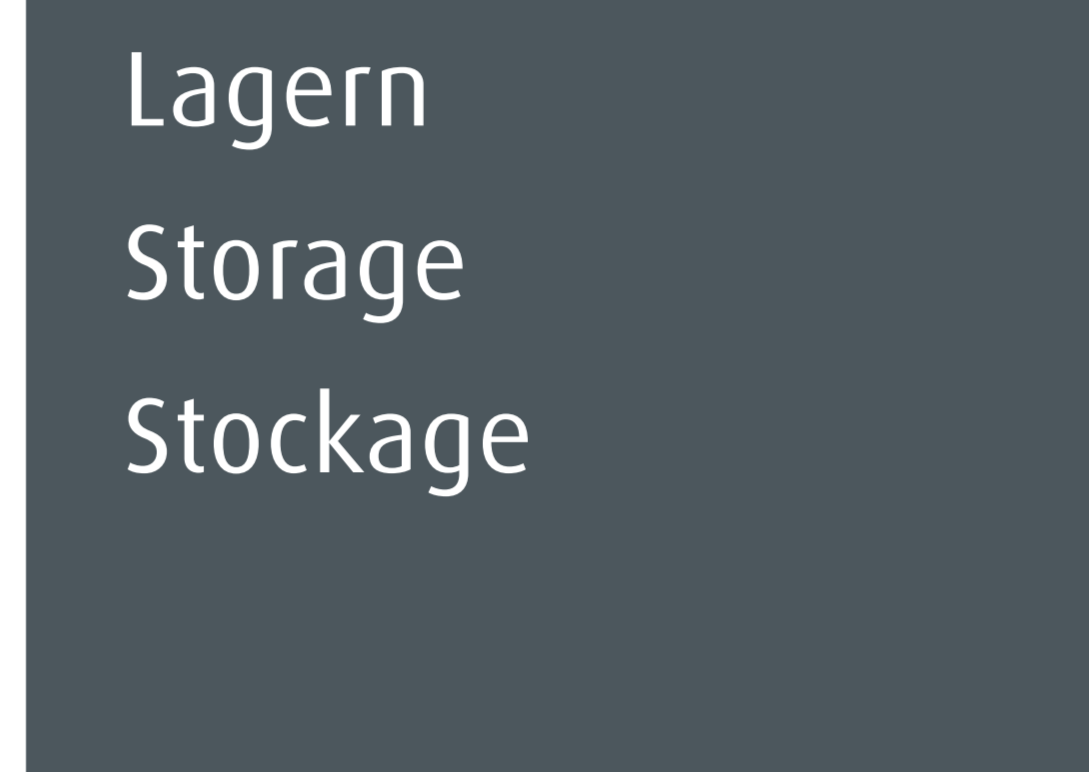
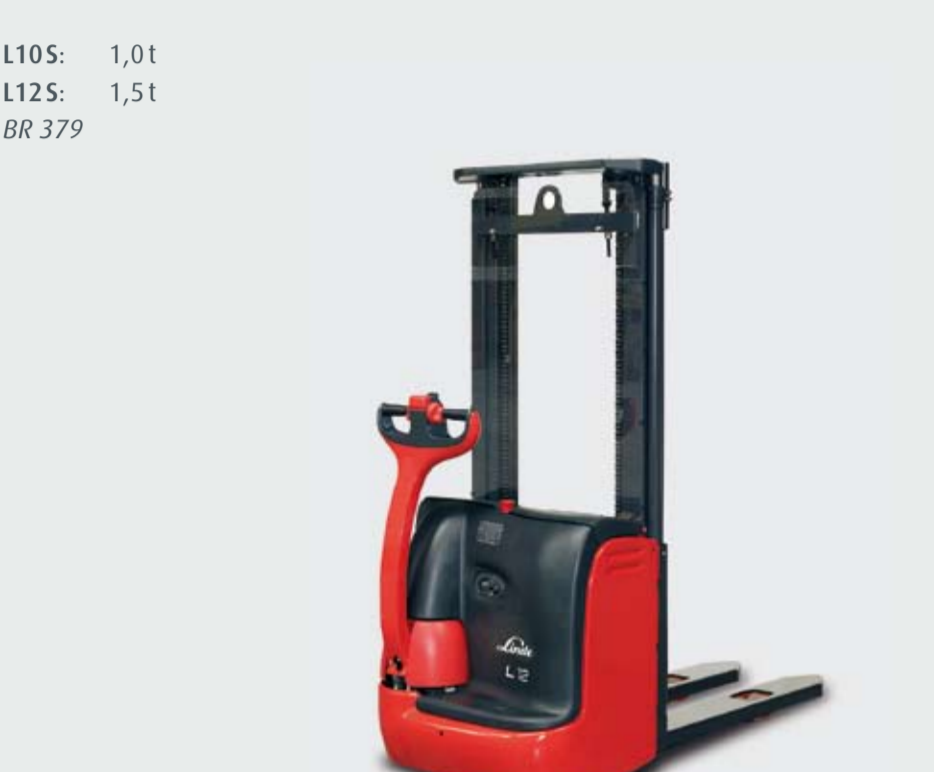
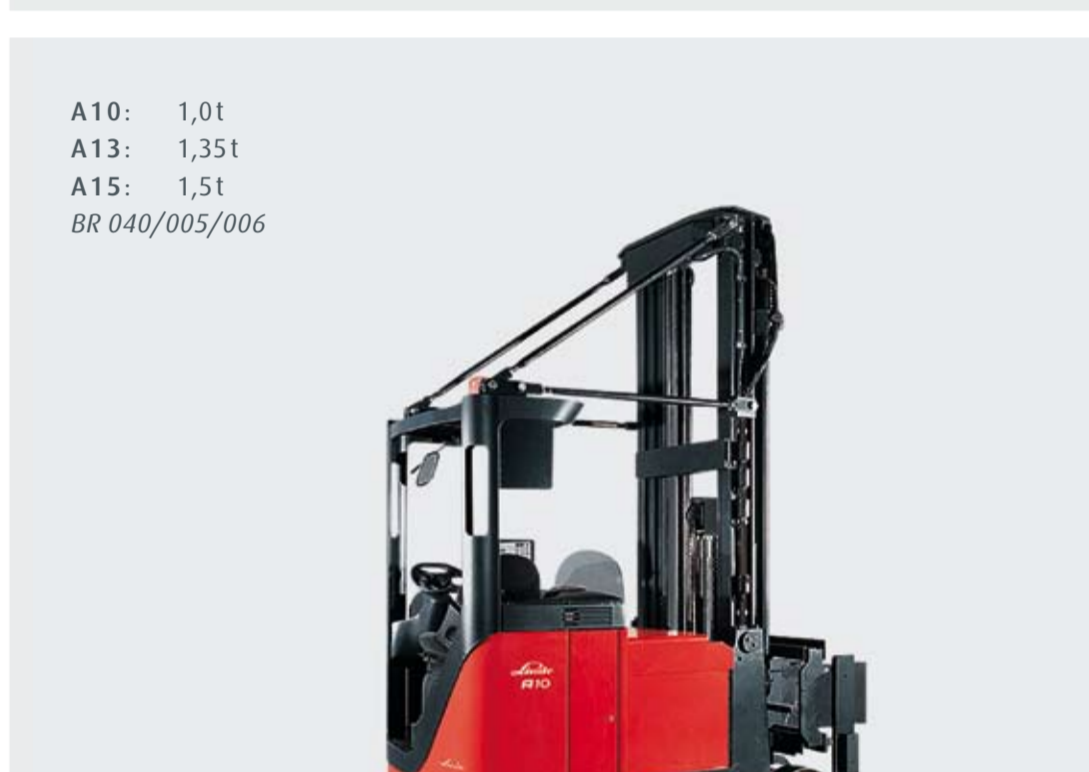
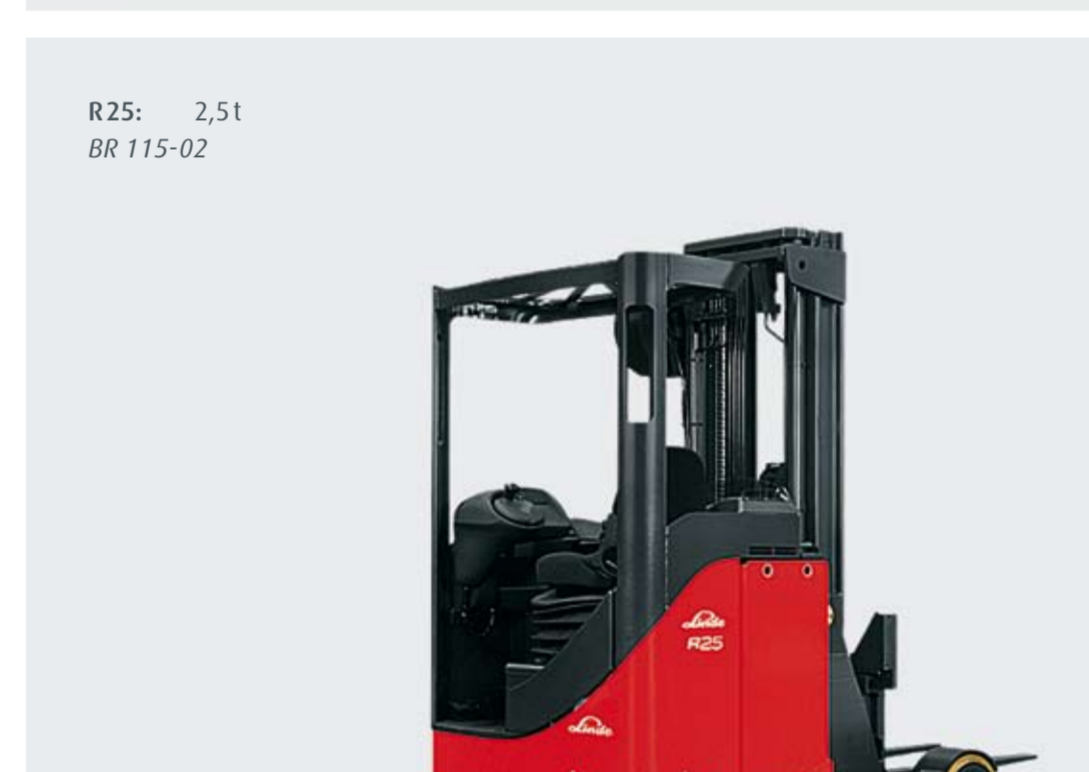
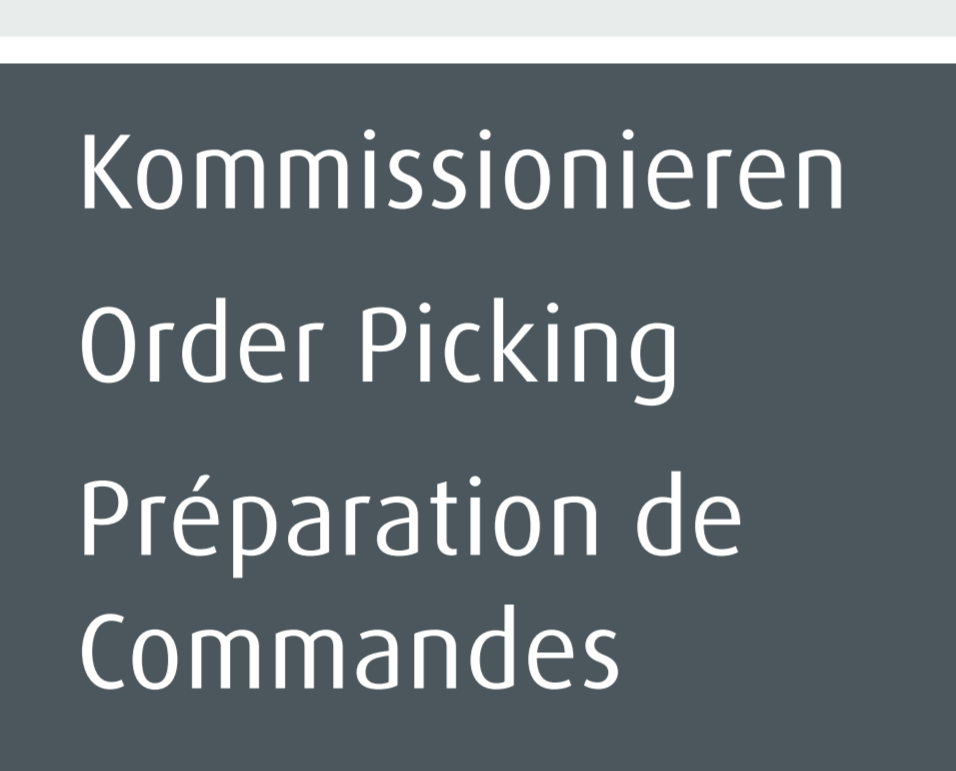
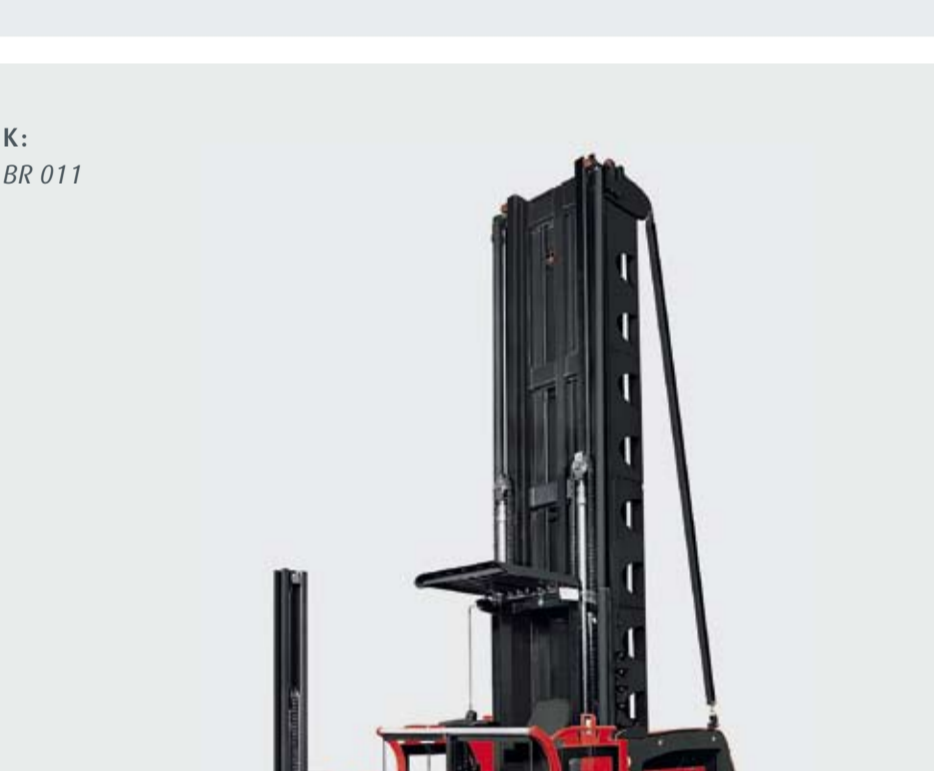
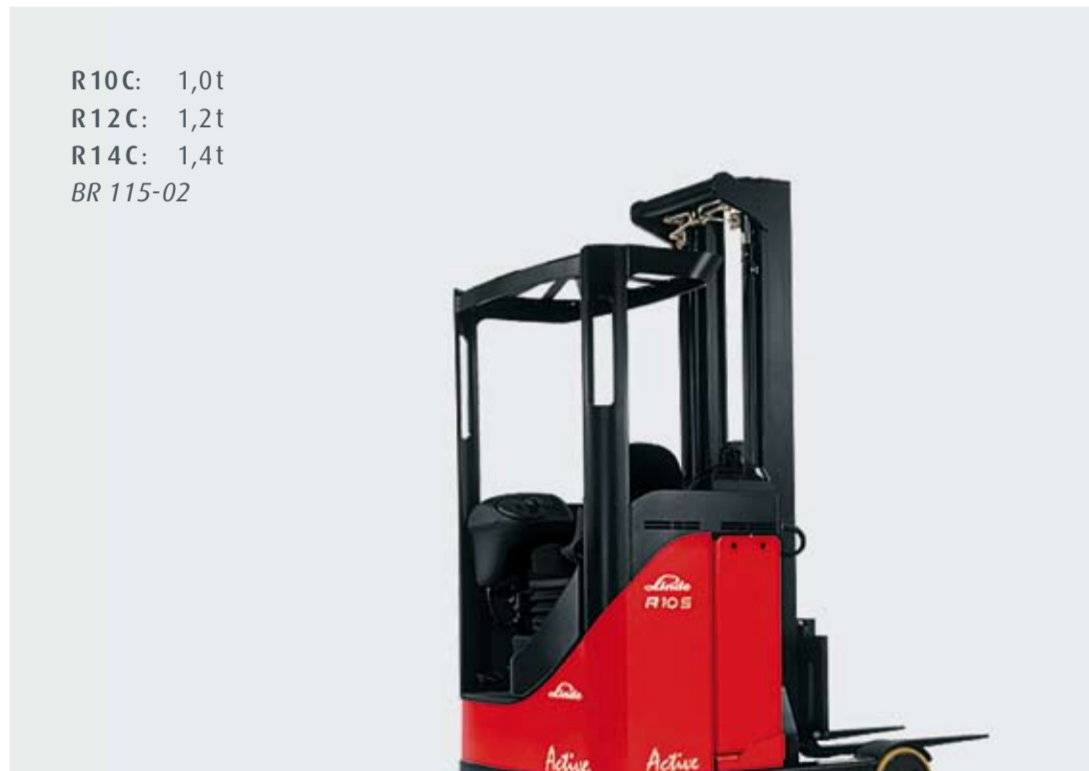
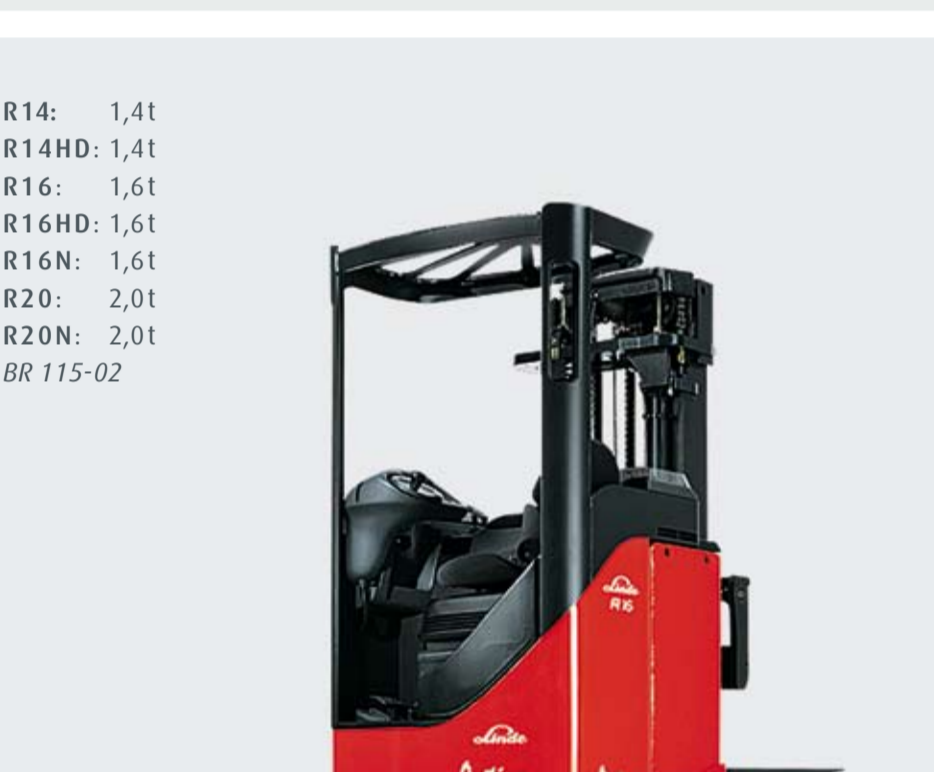

Kommissionieren  
Order Picking  
Préparation de  
Commandes



Stapeln  
Stacking  
Manutention

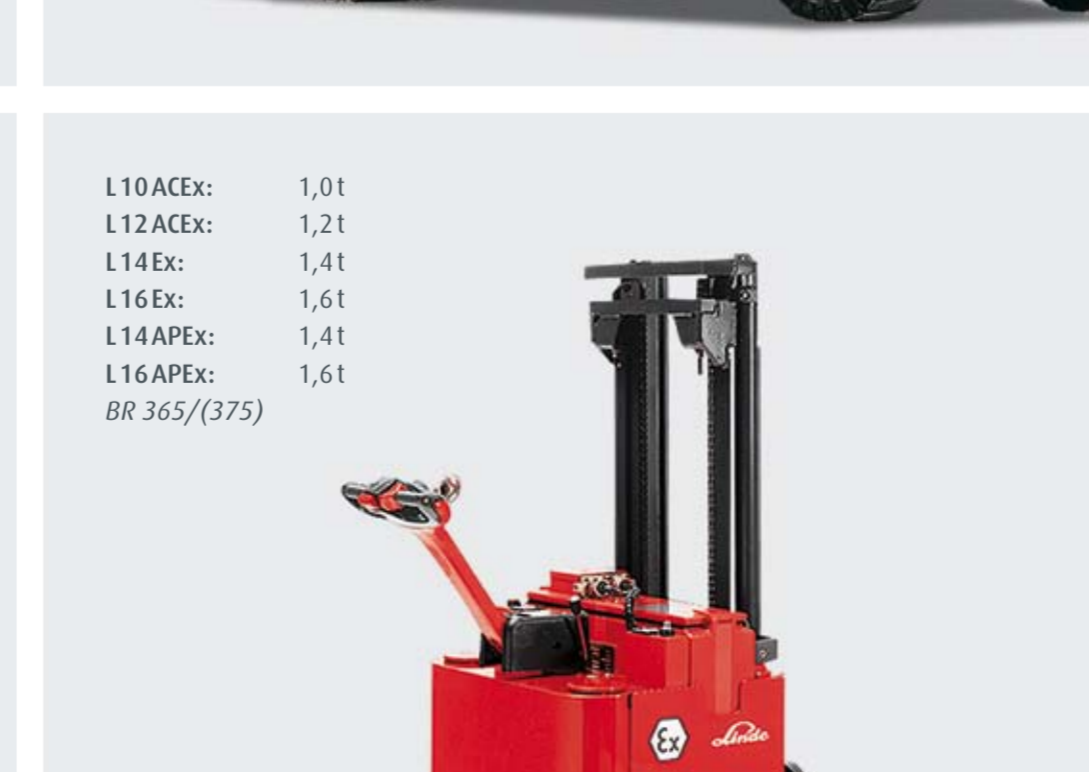
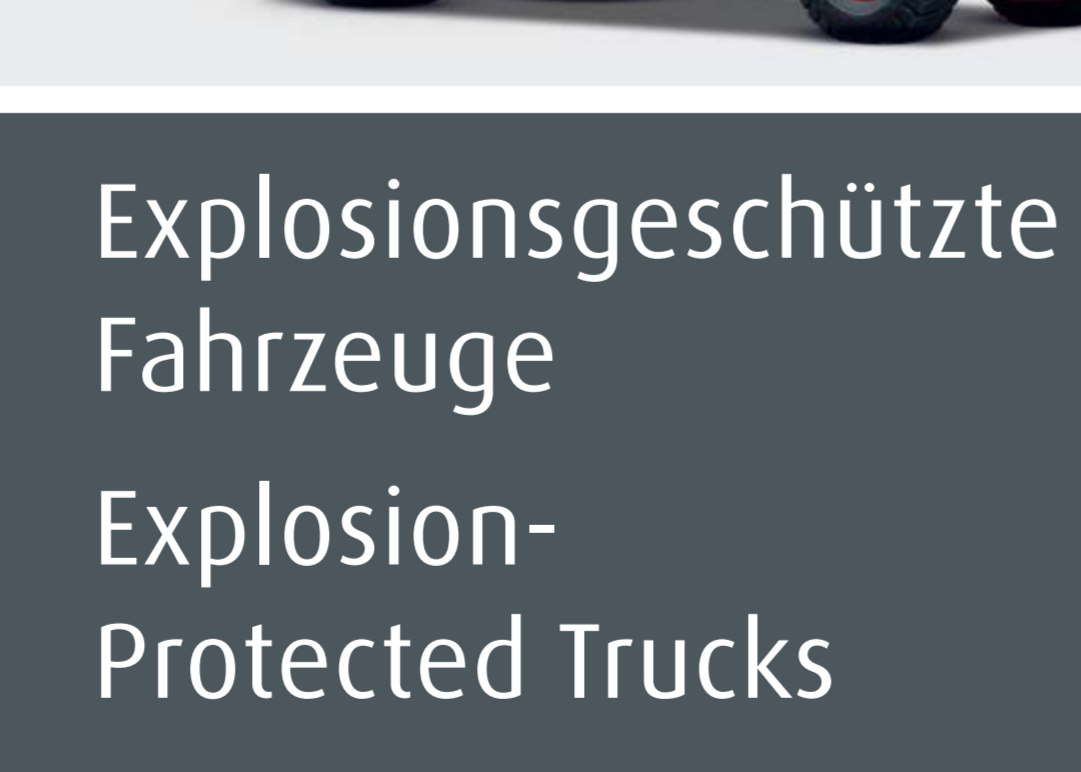
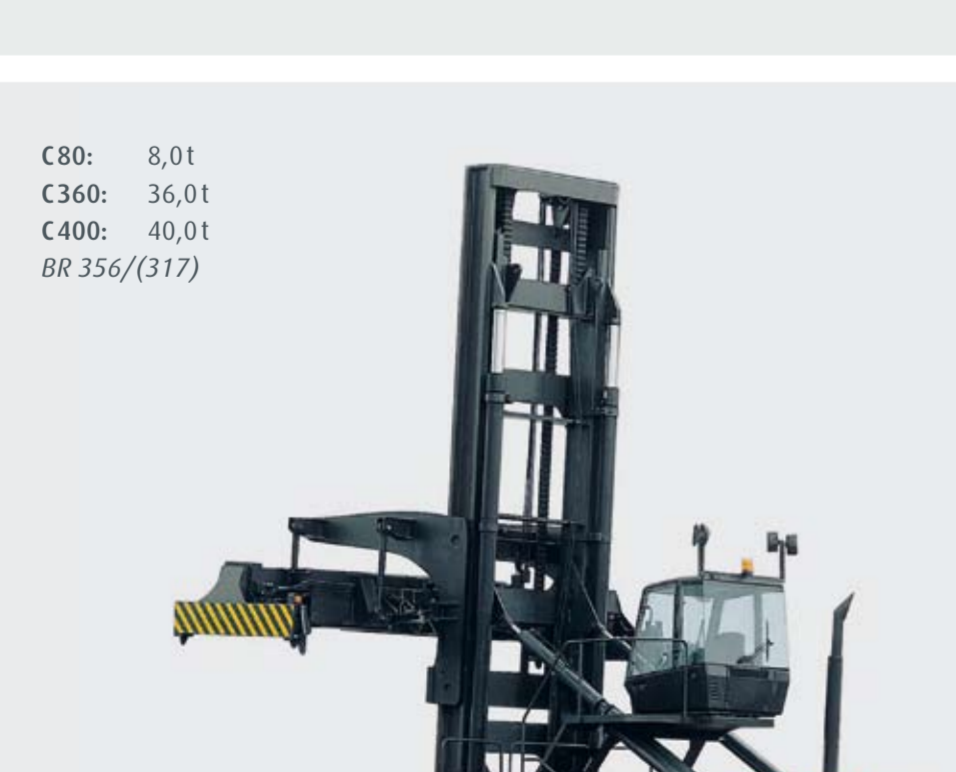
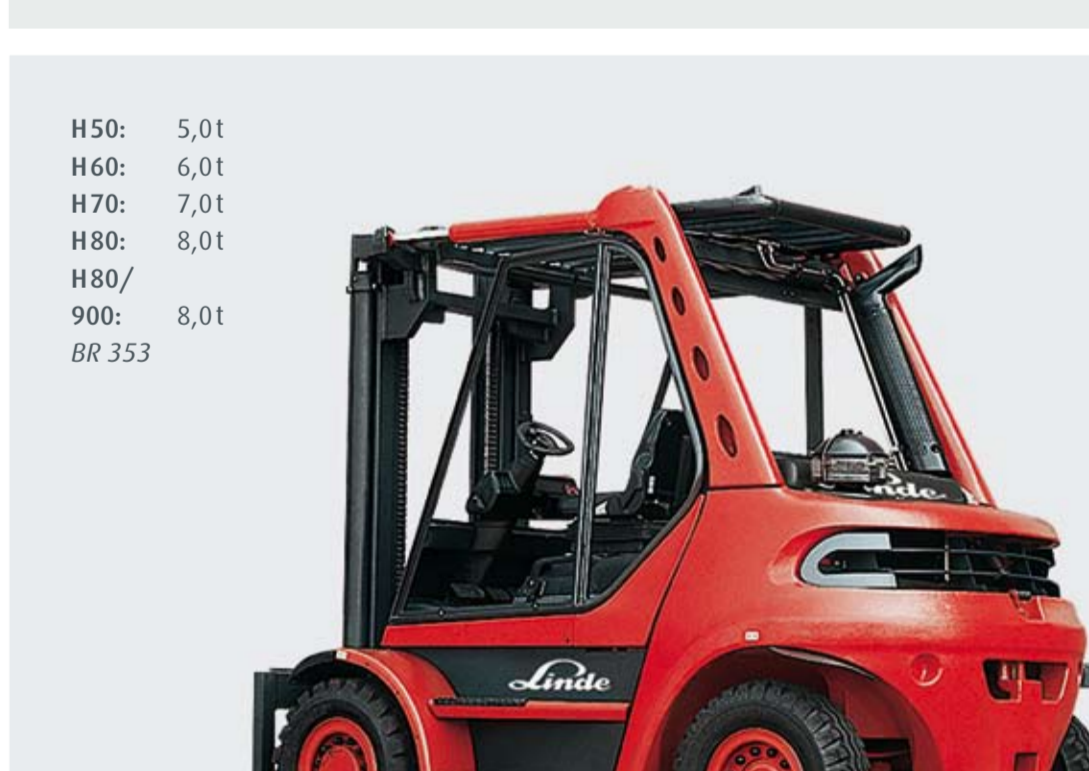
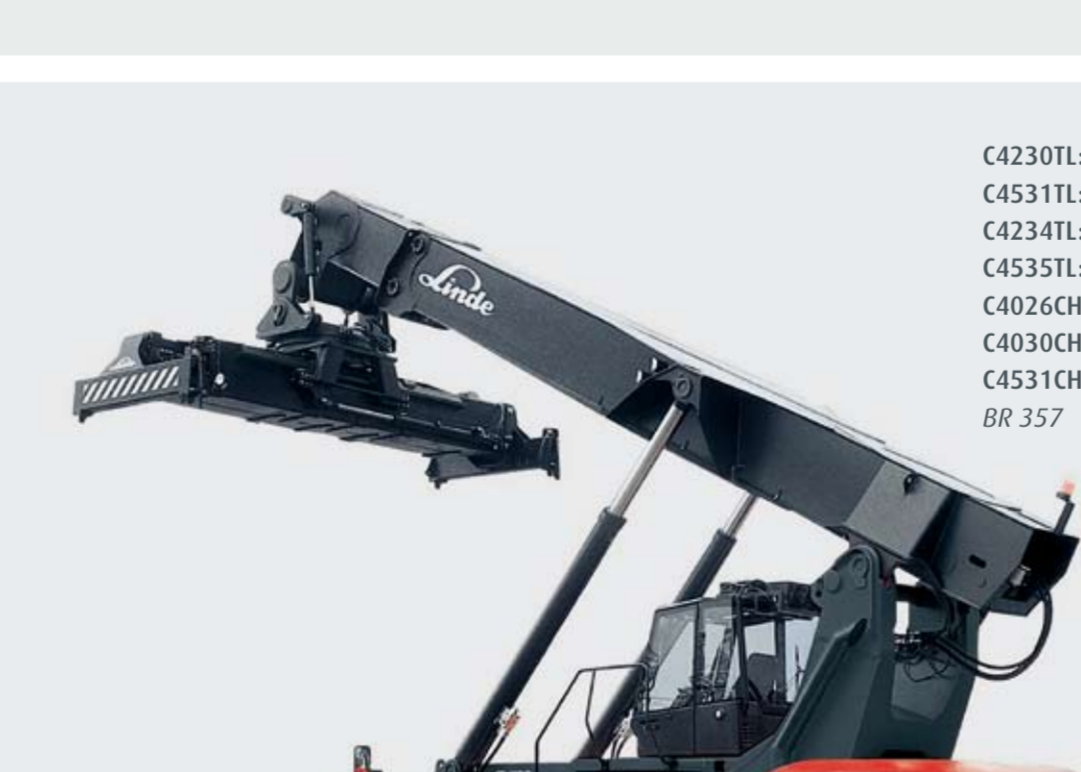
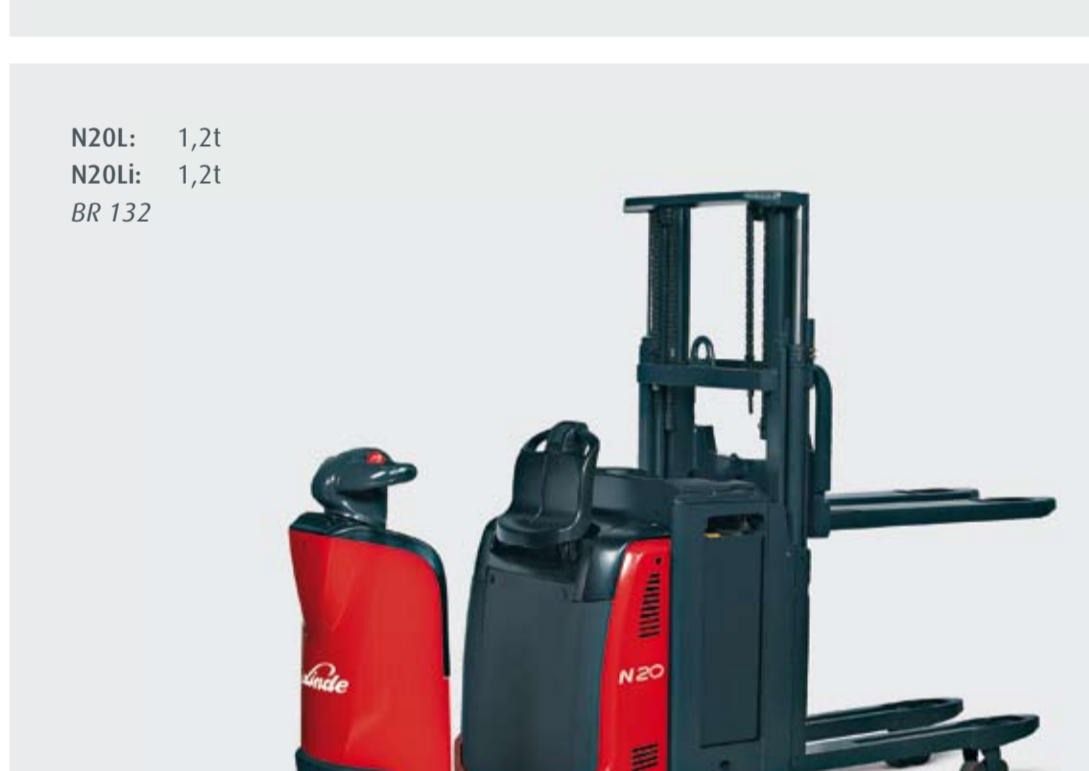
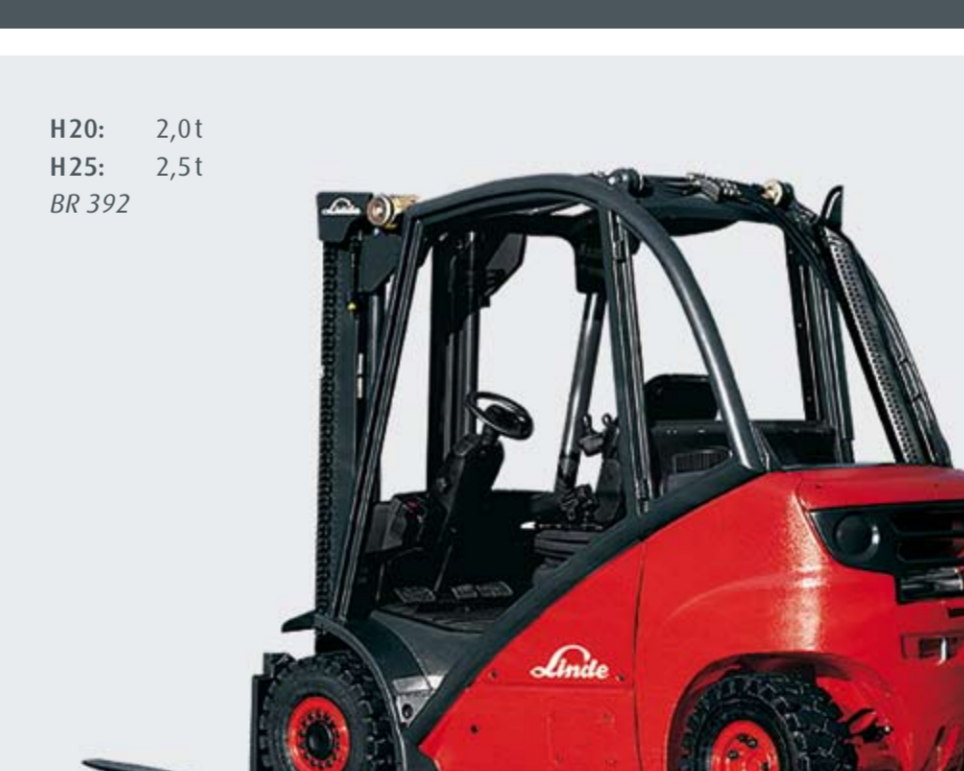
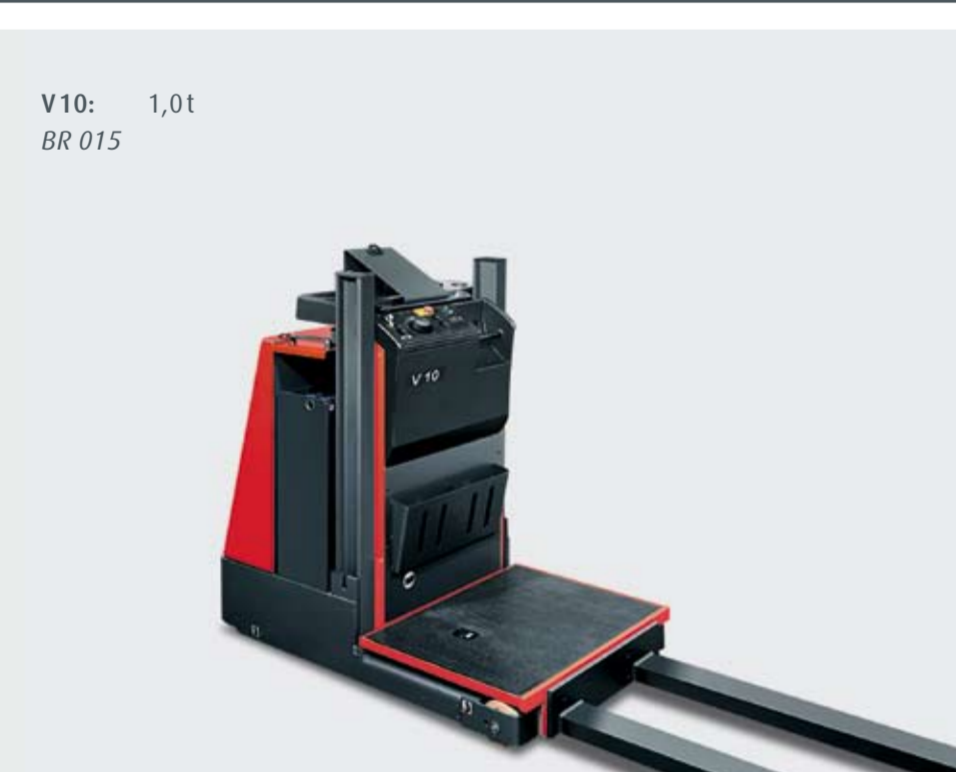
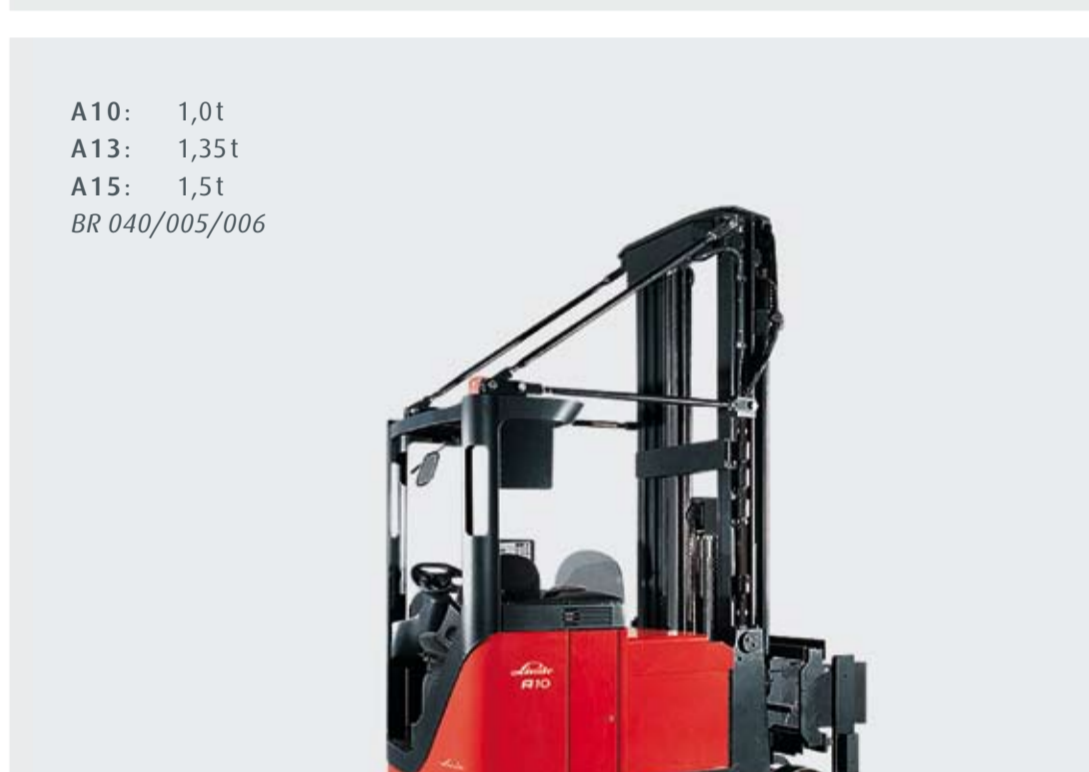

Stapeln  
Stacking  
Manutention

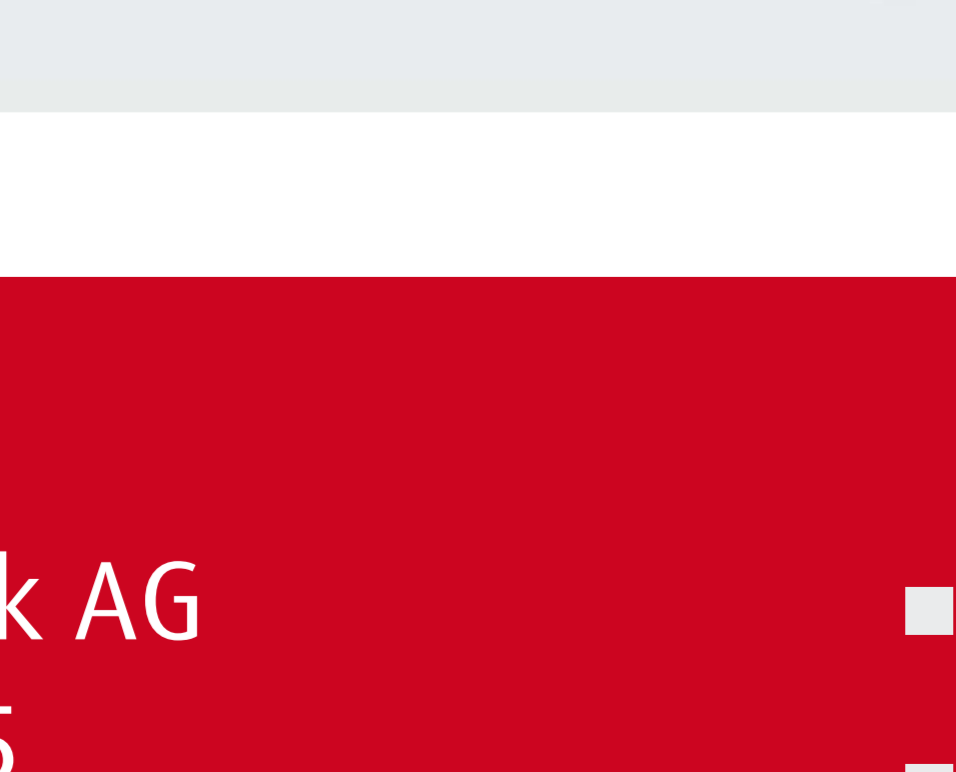
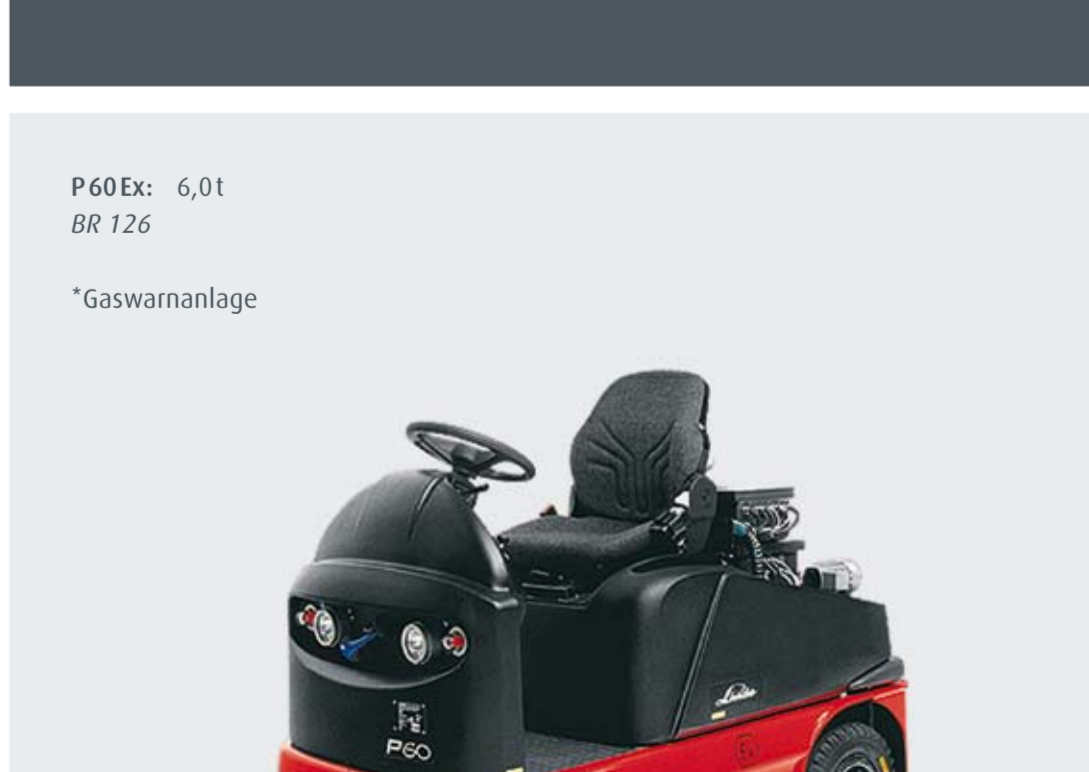
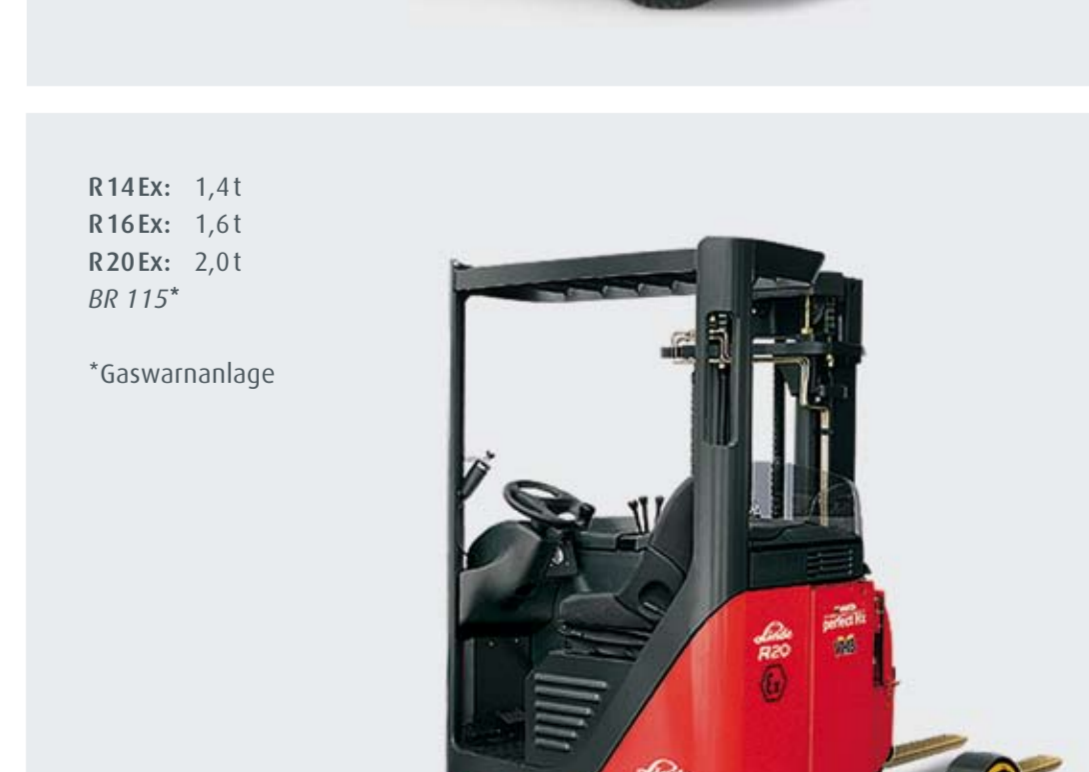
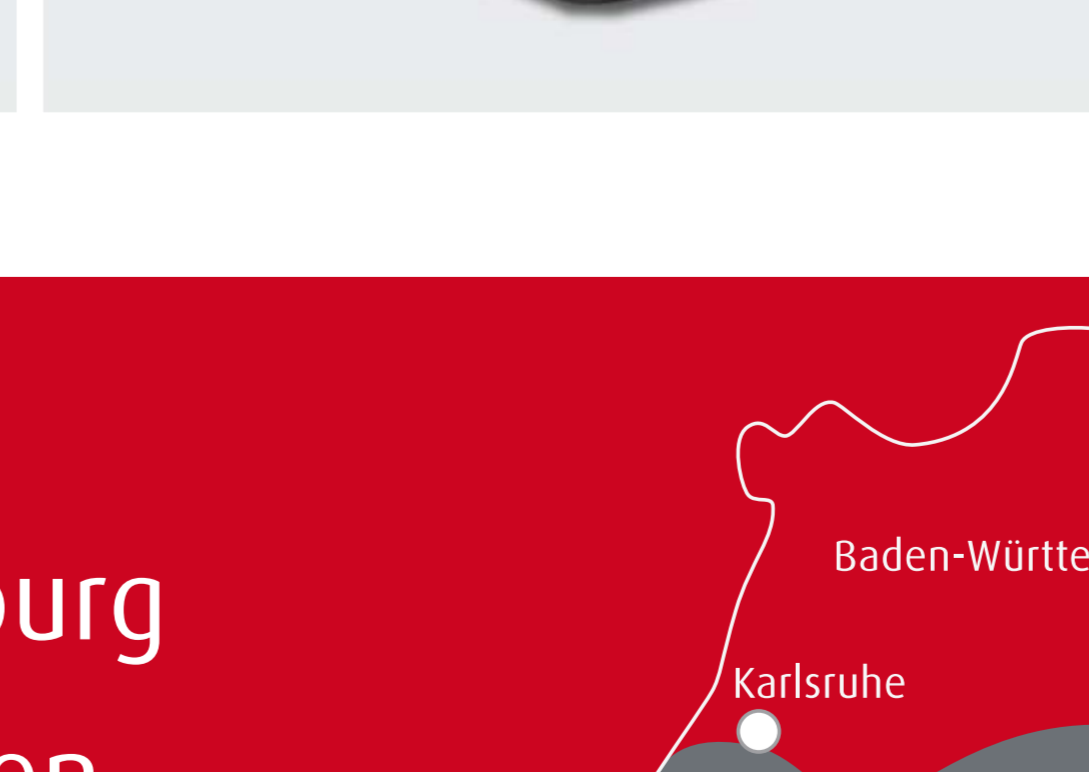
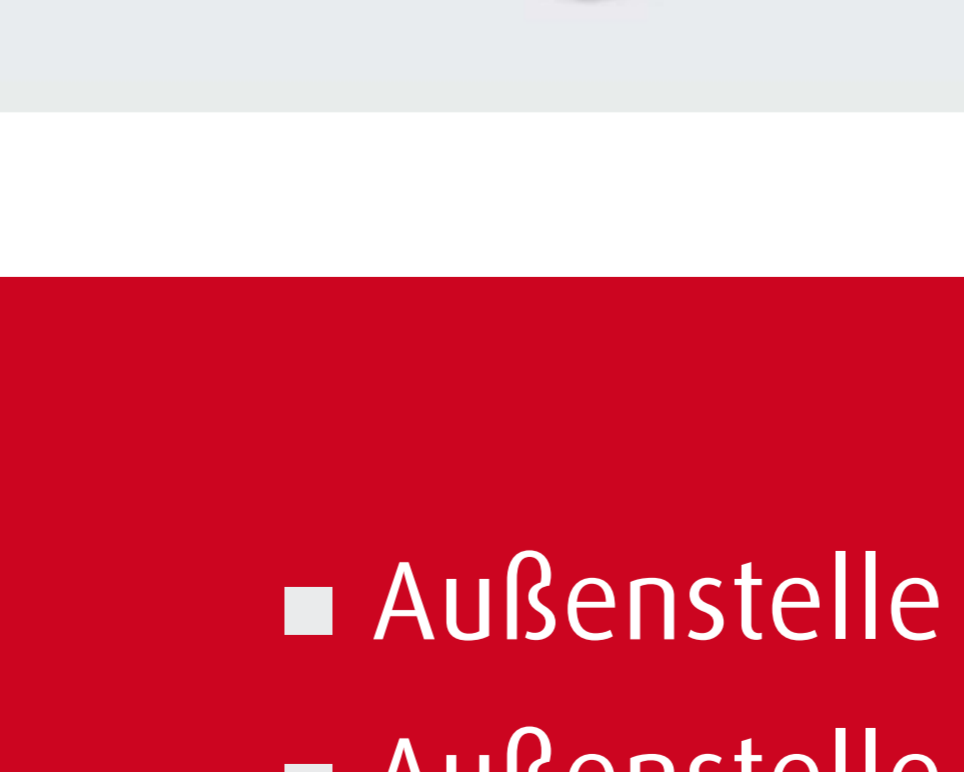
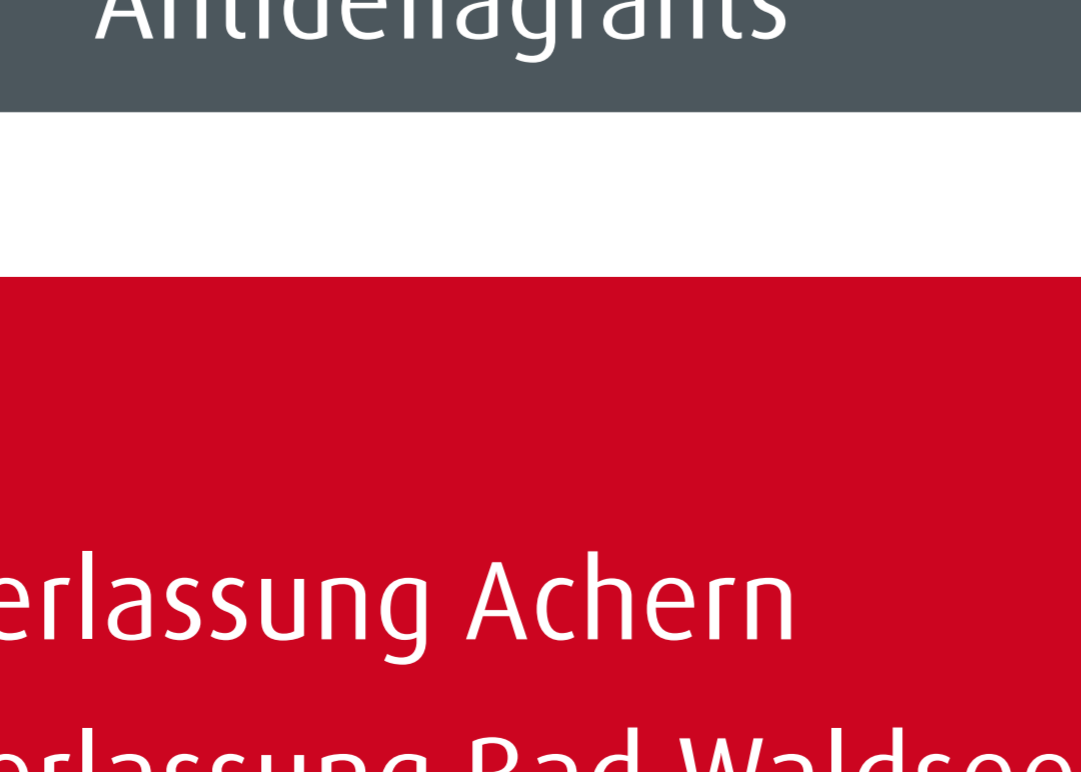
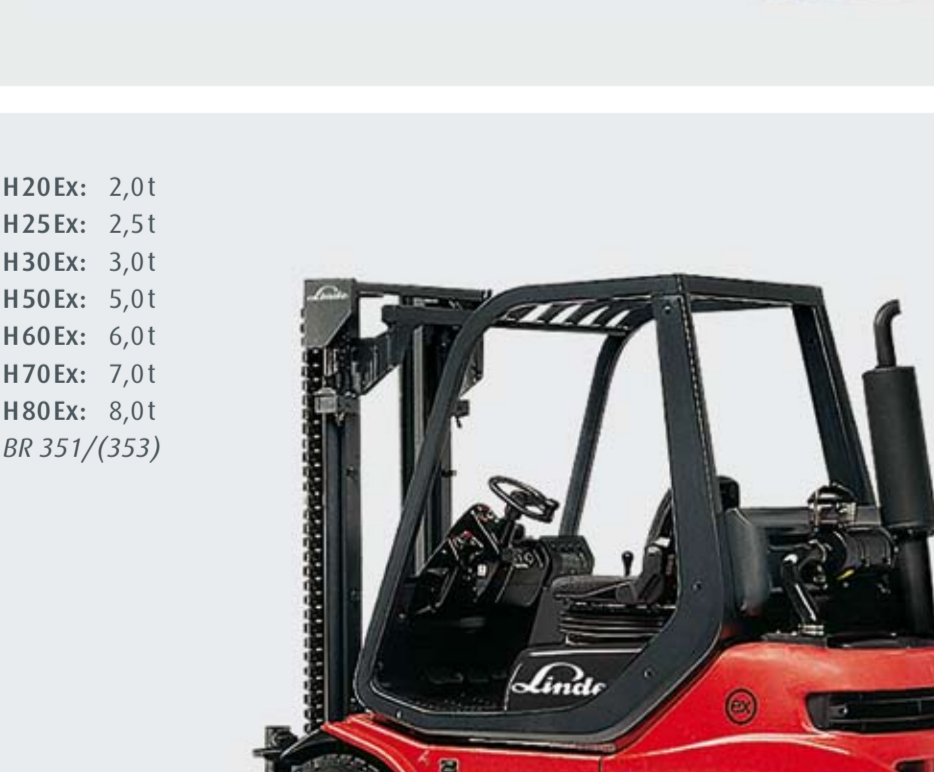
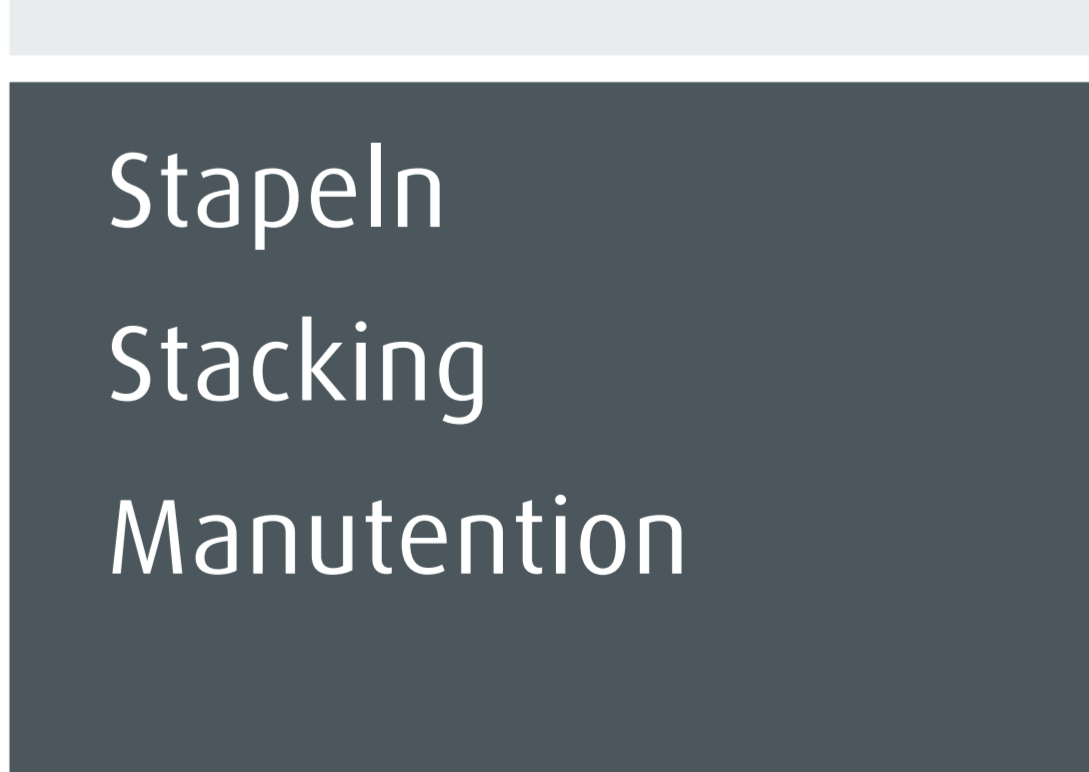

Explosionsschutz  
Fahrzeuge  
Explosion-  
Protected Trucks  
Chariots  
Antidéflagrants



# Alles aus einer Hand!

■ Schöler Fördertechnik AG  
Robert-Bosch-Str. 3-5  
79618 Rheinfelden  
Telefon 0 76 23/9 63-0  
info@schoeler-gabelstapler.de

■ Niederlassung Achern  
■ Niederlassung Bad Waldsee  
■ Niederlassung Schramberg  
■ Niederlassung Stuttgart

■ Außenstelle Freiburg  
■ Außenstelle Singen  
■ Außenstelle Ulm

